

NCERT Solutions Class 10 Maths Chapter 5 Arithmetic Progressions

Exercise 5.4

1. Which term of the AP : 121, 117, 113, . . . , is its first negative term? [Hint : Find n for an < 0]

Solution: Given the AP series is 121, 117, 113, . . . ,
 Thus, first term, a = 121
 Common difference, d = 117-121= -4

By the nth term formula, a_n
 $= a + (n - 1)d$

Therefore,
 $a_n = 121 + (n - 1)(-4)$
 $= 121 - 4n + 4$
 $= 125 - 4n$

To find the first negative term of the series, $a_n < 0$
 Therefore,
 $125 - 4n < 0$
 $125 < 4n$
 $n > 125/4$
 $n > 31.25$

Therefore, the first negative term of the series is 32nd term.

2. The sum of the third and the seventh terms of an AP is 6 and their product is 8. Find the sum of first sixteen terms of the AP.

Solution: From the given statements, we can write,

$$a_3 + a_7 = 6 \dots\dots\dots(i)$$

And $a_3 \times a_7 = 8$
 $\dots\dots\dots(ii)$

By the nth term formula, a_n
 $= a + (n - 1)d$

Third term, $a_3 = a + (3 - 1)d$
 $a_3 = a + 2d \dots\dots\dots(iii)$

And Seventh term, $a_7 = a + (7 - 1)d$
 $a_7 = a + 6d \dots\dots\dots(iv)$

From equation (iii) and (iv), putting in equation(i), we get,
 $a + 2d + a + 6d = 6$
 $2a + 8d = 6$
 $a + 4d = 3$

NCERT Solutions Class 10 Maths Chapter 5 Arithmetic Progressions

or

$$a = 3 - 4d \dots\dots\dots(v)$$

Again putting the eq. (iii) and (iv), in eq. (ii), we get,

$$(a + 2d) \times (a + 6d) = 8$$

Putting the value of a from equation (v), we get,

$$(3 - 4d + 2d) \times (3 - 4d + 6d) = 8$$

$$(3 - 2d) \times (3 + 2d) = 8$$

$$3^2 - 2d^2 = 8$$

$$9 - 4d^2 = 8 \quad 4d^2$$

$$= 1 \quad d = 1/2 \quad \text{or}$$

$$-1/2$$

Now, by putting both the values of d, we get,

$$a = 3 - 4d = 3 - 4(1/2) = 3 - 2 = 1, \text{ when } d = 1/2$$

$$= 3 - 4d = 3 - 4(-1/2) = 3 + 2 = 5, \text{ when } d = -1/2$$

We know, the sum of nth term of AP is;

$$S_n = n/2 [2a + (n - 1)d]$$

So, when $a = 1$ and $d = 1/2$

Then, the sum of first 16 terms are;

$$S_{16} = 16/2 [2 + (16 - 1)1/2] = 8(2 + 15/2) = 76$$

And when $a = 5$ and $d = -1/2$

Then, the sum of first 16 terms are;

$$S_{16} = 16/2 [2.5 + (16 - 1)(-1/2)] = 8(5/2) = 20$$

3. A ladder has rungs 25 cm apart. (see Fig. 5.7). The rungs decrease uniformly in length from 45 cm at the bottom to 25 cm at the top. If the top and the bottom rungs are $2\frac{1}{2}$ m apart, what is the length of the wood required for the rungs? [Hint : Number of rungs = $-250/25$].

NCERT Solutions Class 10 Maths Chapter 5 Arithmetic Progressions

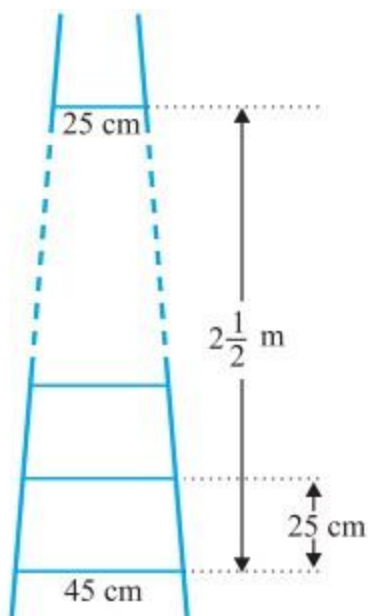

Solution: Given,

Distance between the rungs of the ladder is 25cm.

Distance between the top rung and bottom rung of the ladder is=
= 250cm

Therefore, total number of rungs = $250/25 + 1 = 11$

$$2\frac{1}{2}\text{m} = 2\frac{1}{2} \times 100 \text{ cm} = \frac{5}{2} \times 100 \text{ cm}$$

As we can see from the figure, the ladder has rungs in decreasing order from top to bottom. Thus, we can conclude now, that the rungs are decreasing in an order of AP.

And the length of the wood required for the rungs will be equal to the sum of the terms of AP series formed. So,

First term, $a = 45$

Last term, $l = 25$

Number of terms, $n = 11$

Now, as we know, sum of n th terms is equal to,

$$S_n = n/2(a + l)$$

$$S_n = 11/2(45+25) = 11/2 (70) = 385 \text{ cm}$$

Hence, the length of the wood required for the rungs is 385cm.

NCERT Solutions Class 10 Maths Chapter 5 Arithmetic Progressions

4. The houses of a row are numbered consecutively from 1 to 49. Show that there is a value of x such that the sum of the numbers of the houses preceding the house numbered x is equal to the sum of the numbers of the houses following it. Find this value of x . [Hint : $S_{x-1} = S_{49-x}$]

Solution: Given,

Row houses are numbers from 1,2,3,4,5.....49.

Thus we can see the houses numbered in a row are in the form of AP.

So,

First term, $a = 1$

Common difference, $d=1$

Let us say the number of x th houses can be represented as;

Sum of n th term of AP = $n/2[2a+(n-1)d]$

Sum of number of houses beyond x house = S_{x-1}

$$= (x-1)/2[2.1+(x-1)1]$$

$$= (x-1)/2 [2+x-2]$$

$$= \frac{[x(x-1)]}{2} \dots \dots \dots (i)$$

By the given condition, we can write,

$$S_{49} - S_x = \{49/2[2.1+(49-1)1]\} - \{x/2[2.1+(x-1)1]\}$$

$$= 25(49) - x(x+1)/2 \dots \dots \dots (ii)$$

As per the given condition, eq.(i) and eq(ii) are equal to each other; Therefore,

$$\frac{[x(x-1)]}{2} = 25(49) - \frac{x(x+1)}{2}$$

$$x = \pm 35$$

As we know, the number of house cannot be an a negative number. Hence, the value of x is 35.

5. A small terrace at a football ground comprises of 15 steps each of which is 50 m long and built of solid concrete. Each step has a rise of 14 m and a tread of 12 m. (see Fig. 5.8). Calculate the total volume of concrete required to build the terrace. [Hint : Volume of concrete required to build the first step $= \frac{1}{2} \times \frac{1}{2} \times 50 \text{ m}^3$].

NCERT Solutions Class 10 Maths Chapter 5 Arithmetic Progressions

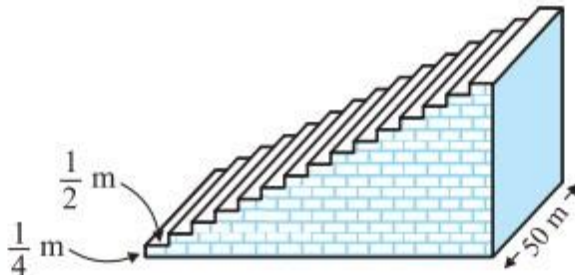

Solution: As we can see from the given figure, the first step is $\frac{1}{2}$ m wide, 2nd step is 1m wide and 3rd step is $\frac{3}{2}$ m wide. Thus we can understand that the width of step by $\frac{1}{2}$ m each time when height is $\frac{1}{4}$ m. And also, given length of the steps is 50m all the time. So, the width of steps forms a series AP in such a way that;
 $\frac{1}{2}, 1, \frac{3}{2}, 2, \dots$

Volume of steps = Volume of Cuboid
 = Length \times Breadth \times Height

Now,

$$\text{Volume of concrete required to build the first step} = \frac{1}{4} \times \frac{1}{2} \times 50 = \frac{25}{4}$$

$$\text{Volume of concrete required to build the second step} = \frac{1}{4} \times 1 \times 50 = \frac{25}{2}$$

$$\text{Volume of concrete required to build the second step} = \frac{1}{4} \times \frac{3}{2} \times 50 = \frac{75}{2}$$

Now, we can see the volumes of concrete required to build the steps, are in AP series;

$$\frac{25}{4}, \frac{25}{2}, \frac{75}{2}, \dots$$

Thus, applying the AP series concept, First

$$\text{term, } a = \frac{25}{4}$$

$$\text{Common difference, } d = \frac{25}{2} - \frac{25}{4} = \frac{25}{4}$$

As we know, the sum of nth term is;

$$S_n = n/2[2a+(n-1)d] = \frac{15}{2} \left[2 \cdot \frac{25}{4} + \left(\frac{15}{2} - 1 \right) \frac{25}{4} \right]$$

Upon solving, we get,

$$S_n = \frac{15}{2} (100)$$

$$S_n = 750$$

NCERT Solutions Class 10 Maths Chapter 5 Arithmetic Progressions

Hence, the total volume of concrete required to build the terrace is 750 m^3 .

edugrooss.com